

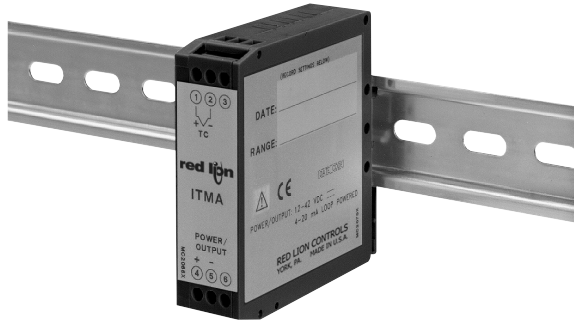

## MODEL ITMA - INTELLIGENT THERMOCOUPLE MODULE WITH ANALOG OUTPUT



- USER PROGRAMMABLE INPUT (THERMOCOUPLE TYPES J, K, T, & E, OR MILLIVOLT)
- 12 TO 42 VDC LOOP POWERED (4 TO 20 MA OUTPUT)
- MICROPROCESSOR CONTROLLED
- SIMPLE ADJUSTABLE RANGE SETTING (USING INPUT SIGNAL)
- THERMOCOUPLE BREAK DETECTION
- MOUNTS ON "T" AND "G" STYLE DIN RAILS
- 2-WAY ELECTRICAL ISOLATION (INPUT/OUTPUT & POWER)
- HIGH-DENSITY PACKAGING (22.5 MM WIDE)
- WIDE OPERATING TEMPERATURE RANGE



### DESCRIPTION

The ITMA accepts a thermocouple or millivolt input and converts it into a 4 to 20 mA current output. The 4 to 20 mA output is linearly proportional to the temperature or the millivolt input. This output is ideal for interfacing to indicators, chart recorders, controllers, or other instrumentation equipment.

The ITMA is loop-powered which means that the same two wires are carrying both the power and the output signal. The unit controls the output current draw from 4 to 20 mA in direct proportion to the input change while consuming less than 4 mA for power. The conversion to a current output signal makes the ITMA less susceptible to noise interference and allows accurate transmission over long distances. The 2-Way isolation allows the use of grounded thermocouples which can provide additional noise reduction benefits.

The ITMA uses a ten position DIP switch to accomplish the input sensor configuration, range selection, and unit calibration. A simple range setting technique (Field Calibration) is used so the actual input signal adjusts the output current for scaling. This technique eliminates the need for potentiometers which are vulnerable to changes due to vibration.

The unit is equipped with a universal mounting foot for attachment to standard DIN style mounting rails, including top hat rail (T) according to EN 50 022 - 35 x 7.5 and 35 x 15, and G profile according to EN 50 035 - G 32.

### SAFETY SUMMARY

All safety related regulations, local codes and instructions that appear in the manual or on equipment must be observed to ensure personal safety and to prevent damage to either the instrument or equipment connected to it. If equipment is used in a manner not specified by the manufacturer, the protection provided by the equipment may be impaired.

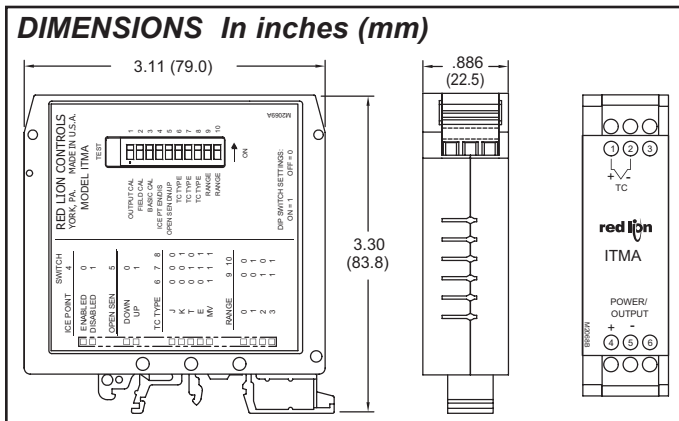

CAUTION: Read complete Instructions prior to installation and operation of the unit.

### SPECIFICATIONS

- POWER:** 12 to 42 VDC \*(Loop powered). The power supply must have a 30 mA min. capacity.  
[\* Min. voltage must be increased to include the drop across any current display indicator]
- INPUT:** J, K, T, E, mV [selectable via DIP switch]
- OUTPUT:** Loop powered (passive), 4 to 20 mA Linear output  
**Ripple:** Less than 15 mV peak-to-peak max., across 250Ω load resistor (up to 120 Hz frequencies).
- RANGE & ACCURACY:** (12 Bit resolution)  
**Accuracy:** ± ( 0.075% Range + 0.25°C [Conformity] + 0.50°C [Ice Point]) at 23°C after 20 min. warm-up, conforming to ITS-90.  
*Note: TC Conformity and Ice Point do not apply to mV input.*  
**Relative Humidity:** Less than 85% RH (non-condensing)  
**Span:** The input span can be set to a min. of 1/8 of the full scale range, anywhere within that range.

Thermocouple Accuracy for each type and the corresponding ranges:

TC (INPUT)	RANGE	DIP SWITCH TYPE RANGE 6 7 8 9 10	TEMPERATURE & mV RANGE	RANGE ACCURACY	WIRE COLOR	
					ANSI	BS1843
J	0	0 0 0 0 0	-136 to 111°C	± 0.19°C	White (+) Red (-)	Yellow (+) Blue (-)
	1	0 0 0 0 1	69 to 575°C	± 0.38°C		
	2	0 0 0 1 0	338 to 800°C	± 0.35°C		
K	0	0 0 1 0 0	-200 to 541°C	± 0.56°C	Yellow (+) Red (-)	Brown (+) Blue (-)
	1	0 0 1 0 1	427 to 1132°C	± 0.53°C		
	2	0 0 1 1 0	648 to 1372°C	± 0.54°C		
T	0	0 1 0 0 0	-225 to 149°C	± 0.28°C	Blue (+) Red (-)	White (+) Blue (-)
	1	0 1 0 0 1	74 to 326°C	± 0.19°C		
	2	0 1 0 1 0	68 to 400°C	± 0.25°C		
E	0	0 1 1 0 0	-111 to 311°C	± 0.32°C	Violet (+) Red (-)	Brown (+) Blue (-)
	1	0 1 1 0 1	276 to 609°C	± 0.25°C		
	2	0 1 1 1 0	377 to 1000°C	± 0.47°C		
mV	0	1 1 1 0 0	-9 to 6 mV	± 0.0113 mV	N/A	N/A
	1	1 1 1 0 1	-9 to 22 mV	± 0.0233 mV		
	2	1 1 1 1 0	-9 to 63 mV	± 0.0540 mV		
3	1 1 1 1 1	-9 to 77 mV	± 0.0645 mV			

Note: DIP switch settings ON = 1 OFF = 0

### ORDERING INFORMATION

MODEL NO.	DESCRIPTION	PART NUMBER
ITMA	Intelligent Thermocouple Module	ITMA2003

Accuracy Example:  
Type "J" Range "0"  
-136°C to 111°C

Range	Conformity	Ice Point	Total Error
(±0.19°C + ±0.25°C + ±0.50°C) =			±0.94°C

5. **TC BREAK DETECTION:** Upscale to 22.5 mA (nominal) or Downscale to 3.6 mA (nominal) [selectable via DIP switch]
6. **RESPONSE TIME:** 400 msec (to within 99% of final value w/step input; typically, response is limited to response time of probe.)
7. **ENVIRONMENTAL CONDITIONS:**  
**Operating Temperature Range:** -25°C to 75°C (-13°F to 167°F)  
**Storage Temperature Range:** -40°C to 85°C (-40°F to 185°F)  
**Operating and Storage Humidity:** 85% max. (non-condensing) from -25°C to 75°C.  
**Vibration to IEC 68-2-6:** Operational 5-150 Hz, 2 g  
**Shock to IEC 68-2-27:** Operational 30 g  
**Temperature Coefficient:** ± 0.01% of input range per °C  
**Ice Point Compensation:** ± 0.75°C for a 50°C change in temperature  
**Altitude:** Up to 2000 meters.
8. **DIELECTRIC WITHSTAND VOLTAGE:** 1500 VAC for 1 minute, at 50 VAC working volts, from Input to Output
9. **CERTIFICATIONS AND COMPLIANCES:**  
**CE Approved**  
 EN 61326-1 Immunity to Industrial Locations  
 Emission CISPR 11 Class A  
 IEC/EN 61010-1  
*Refer to the EMC Installation Guidelines section of this bulletin for additional information.*
10. **MOUNTING:** Universal mounting foot for attachment to standard DIN style mounting rails, including top hat (T) profile rail according to EN50022 - 35 × 7.5 and 35 × 15, and G profile rail according to EN50035 - G32.
11. **CONNECTION:** Compression type terminal block
12. **CONSTRUCTION:** High impact black plastic case. Installation Category I, Pollution Degree 2.
13. **WEIGHT:** 2.7 oz (76.54 g)

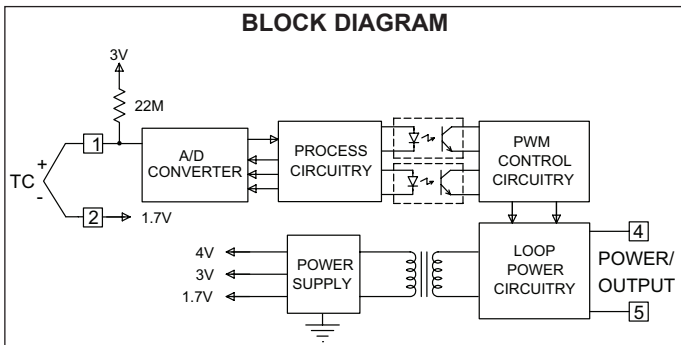

## FUNCTION DESCRIPTIONS

### Open Sensor Detection

The output can be set to go Upscale or Downscale for the detection of an open sensor. The Upscale setting makes the output go to 22.5 mA (nominal). The Downscale setting makes the output go to 3.5 mA (nominal). This setting is always active, so changes in the setting are effective immediately.

### Ice Point Compensation

The Ice Point Compensation for the thermocouple sensors can be enabled (DIP Switch OFF) or disabled (DIP Switch ON). The mV sensor input is not affected by this setting. Generally, the Ice Point Compensation is always enabled.

### Calibration Malfunction

If the unit has scaling problems (current remains at 3.5 mA nominal), check the voltage between the TC- Input (-) and TEST pad (+) [located next to the DIP switches on the side of the unit]. For normal operation the voltage is -1.77 V (nominal). If the voltage is +1.23 V (nominal), a problem occurred storing information in the E<sup>2</sup>PROM. When this happens, perform a Basic Calibration and then a Field Calibration. Turn off power for 5 seconds. Turn on power and check the voltage between the TEST pad (+) and TC- Input (-). If the voltage is still +1.23 V (nominal), contact the factory.

## FACTORY SETTINGS

The unit is shipped from the factory calibrated for a 4 to 20 mA output using a type J thermocouple in range 3. The ITMA should be Field calibrated by the operator for the application environment it will be used in. If the unit is not recalibrated by the operator, the following table lists the temperature ranges for the given thermocouple types.

TYPE	RANGE	TEMPERATURE RANGE
J	3	-50°C to 500°C
K	3	-85°C to 790°C
T	3	-195°C to 162°C
E	3	3°C to 602°C

## WIRING CONNECTIONS

All conductors should meet voltage and current ratings for each terminal. Also, cabling should conform to appropriate standards of good installation, local codes and regulations. It is recommended that power supplied to the unit be protected by a fuse or circuit breaker. When wiring the unit, use the numbers on the label to identify the position number with the proper function. Strip the wire, leaving approximately 1/4" (6 mm) of bare wire exposed (stranded wire should be tinned with solder). Insert the wire into the terminal, and tighten the screw until the wire is clamped tightly.

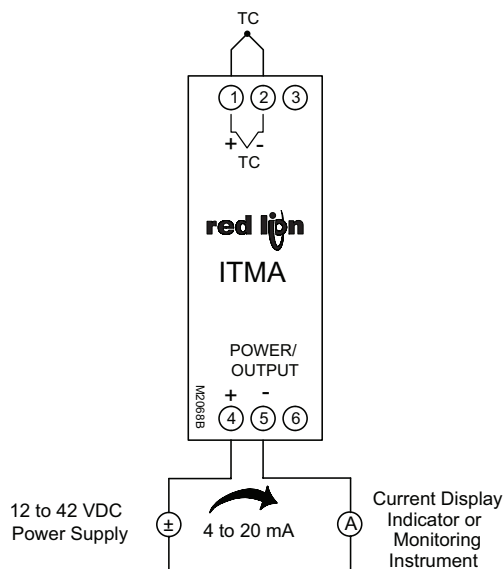

## EMC INSTALLATION GUIDELINES

Although Red Lion Controls Products are designed with a high degree of immunity to Electromagnetic Interference (EMI), proper installation and wiring methods must be followed to ensure compatibility in each application. The type of the electrical noise, source or coupling method into a unit may be different for various installations. Cable length, routing, and shield termination are very important and can mean the difference between a successful or troublesome installation. Listed are some EMI guidelines for a successful installation in an industrial environment.

1. A unit should be mounted in a metal enclosure, which is properly connected to protective earth.
2. Use shielded cables for all Signal and Control inputs. The shield connection should be made as short as possible. The connection point for the shield depends somewhat upon the application. Listed below are the recommended methods of connecting the shield, in order of their effectiveness.
  - a. Connect the shield to earth ground (protective earth) at one end where the unit is mounted.
  - b. Connect the shield to earth ground at both ends of the cable, usually when the noise source frequency is over 1 MHz.
3. Never run Signal or Control cables in the same conduit or raceway with AC power lines, conductors, feeding motors, solenoids, SCR controls, and heaters, etc. The cables should be run through metal conduit that is properly grounded. This is especially useful in applications where cable runs are long and portable two-way radios are used in close proximity or if the installation is near a commercial radio transmitter. Also, Signal or Control cables within an enclosure should be routed as far away as possible from contactors, control relays, transformers, and other noisy components.
4. Long cable runs are more susceptible to EMI pickup than short cable runs.

5. In extremely high EMI environments, the use of external EMI suppression devices such as Ferrite Suppression Cores for signal and control cables is effective. The following EMI suppression devices (or equivalent) are recommended:

Fair-Rite part number 0443167251 (RLC part number FCOR0000)

Line Filters for input power cables:

Schaffner # FN2010-1/07 (Red Lion Controls # LFIL0000)

6. To protect relay contacts that control inductive loads and to minimize radiated and conducted noise (EMI), some type of contact protection network is normally installed across the load, the contacts or both. The most effective location is across the load.

a. Using a snubber, which is a resistor-capacitor (RC) network or metal oxide varistor (MOV) across an AC inductive load is very effective at reducing EMI and increasing relay contact life.

b. If a DC inductive load (such as a DC relay coil) is controlled by a transistor switch, care must be taken not to exceed the breakdown voltage of the transistor when the load is switched. One of the most effective ways is to place a diode across the inductive load. Most RLC products with solid state outputs have internal zener diode protection. However external diode protection at the load is always a good design practice to limit EMI. Although the use of a snubber or varistor could be used.

RLC part numbers: Snubber: SNUB0000

Varistor: ILS11500 or ILS23000

7. Care should be taken when connecting input and output devices to the instrument. When a separate input and output common is provided, they should not be mixed. Therefore a sensor common should NOT be connected to an output common. This would cause EMI on the sensitive input common, which could affect the instrument's operation.

Visit RLC's web site at <http://www.redlion.net/Support/InstallationConsiderations.html> for more information on EMI guidelines, Safety and CE issues as they relate to Red Lion Controls products.

## INPUT AND POWER/OUTPUT CONNECTIONS

### Input

When connecting the thermocouple, be certain that the connections are clean and tight. The negative thermocouple lead is connected to Terminal #2 (TC-) and the positive lead is connected to Terminal #1 (TC+). If the thermocouple probe cannot be connected directly to the module, thermocouple wire or thermocouple extension-grade wire must be used to extend the connection points (copper wire does not work). Always refer to the thermocouple manufacturer's recommendations for mounting, temperature range, shielding, etc.

### Power/Output

The unit has the power and current output sharing the same two wires (loop-powered). Connect DC power to terminals #4 and #5, observing the correct polarity, with a current meter/indicator connected in between so that the output current can be monitored. Be certain that the DC power is relatively "clean" and within the 12 to 42 VDC range at the terminals. The current meter voltage drop must be included in power supply considerations.

### DIP SWITCH SETTING DESCRIPTIONS

SWITCH	DESCRIPTION	
1	OUTPUT CAL	Output Calibration
2	FIELD CAL	Field Calibration
3	BASIC CAL	Basic Calibration
4	ICE PT EN/DIS	Ice Point Compensation - Disabled (ON) / Enabled (OFF)
5	OPEN SEN DN/UP	Open Sensor Detection - Upscale (ON) / Downscale (OFF)
6	TC TYPE	Thermocouple Type - 3 switch combination setting
7		
8		
9	RANGE	Sensor Range - 2 switch combination setting
10		

### TC Type and Range switch settings (ON = 1 OFF = 0)

TC TYPE	DIP SWITCH		
	6	7	8
J	0	0	0
K	0	0	1
T	0	1	0
E	0	1	1
mV	1	1	1

RANGE	DIP SWITCH	
	9	10
0	0	0
1	0	1
2	1	0
3	1	1

# CALIBRATION PROCEDURES

## 1.0 Field Calibration

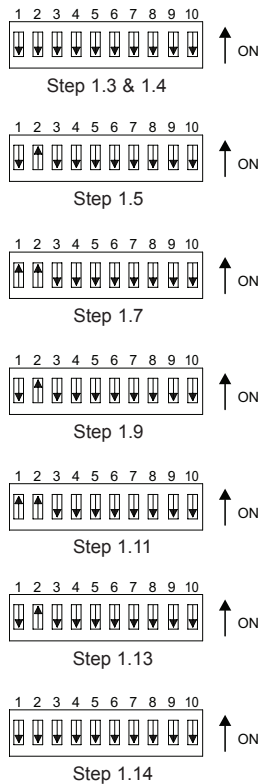
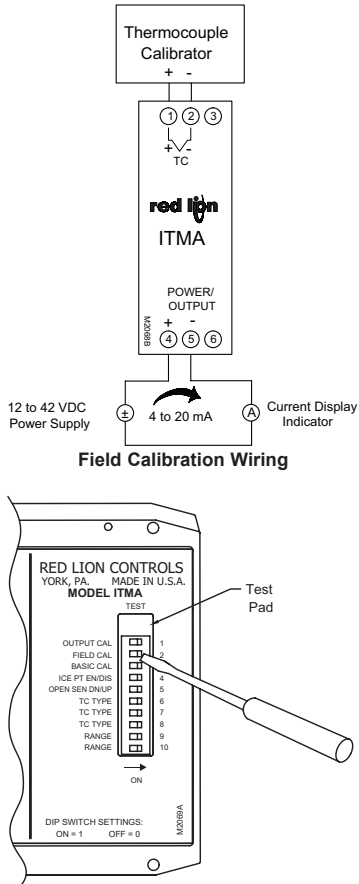

Field Calibration scales the 4 to 20 mA output to a temperature or mV input. This procedure assigns an input value to 4 mA and an input value to 20 mA. The microprocessor handles configuring the output so it is linear to the temperature or mV input. The Field Calibration procedure is described below.

*Note: Allow a 30 minute warm-up period before calibrating. The unit needs to have the Field Calibration completed by the operator before normal operation. To abort this calibration and reset to the previous settings, set the FIELD CAL switch OFF prior to the final OFF setting of the OUTPUT CAL switch (Step 1.13) and turn off power. Wait 5 seconds and then turn on power and the previous settings will be loaded.*

### Field Calibration with a Thermocouple Calibrator

- 1.1 Enable the Ice Point Compensation on the Thermocouple Calibrator and set it to the Thermocouple type being used in your application.
- 1.2 Connect the thermocouple wire as selected in step 1 to the TC input terminals of the ITMA and the thermocouple calibrator.
- 1.3 Set the ICE PT EN/DIS switch (#4) OFF to enable Ice Point Compensation.
- 1.4 Set the Type and Range for the thermocouple or mV used in your application (DIP switches #6 through #10). (TC type "J", Range 0 shown)
- 1.5 Set the FIELD CAL switch (#2) ON. [Current goes to 3.6 mA (nominal)]
- 1.6 Apply the input signal for the 4 mA output.
- 1.7 Set the OUTPUT CAL switch (#1) ON. [Current stays at 3.6 mA (nominal)]
- 1.8 Adjust the input signal up until the output equals 4 mA.
- 1.9 Set the OUTPUT CAL switch (#1) OFF. [Current increases to 22.3 mA (nominal)]
- 1.10 Apply the input signal for the 20 mA output.
- 1.11 Set the OUTPUT CAL switch (#1) ON. [Current decreases to 20.5 mA (nominal)]
- 1.12 Adjust the input signal down until the output equals 20 mA.
- 1.13 Set the OUTPUT CAL switch (#1) OFF.
- 1.14 Set the FIELD CAL switch (#2) OFF.
- 1.15 Disconnect the thermocouple calibrator from the ITMA and connect the actual sensor to be used in the application.

## 2.0 Field Calibration With an Accurate Adjustable Millivolt Source: (Alternate Method)

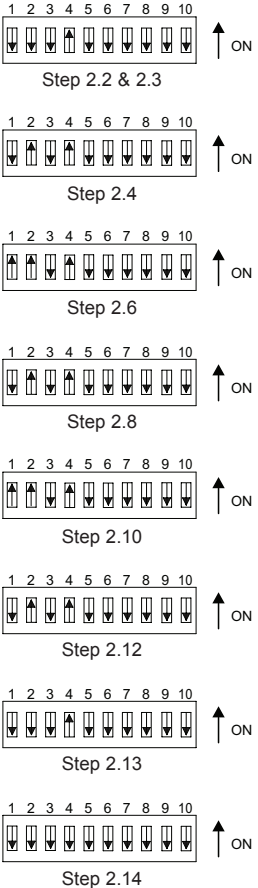
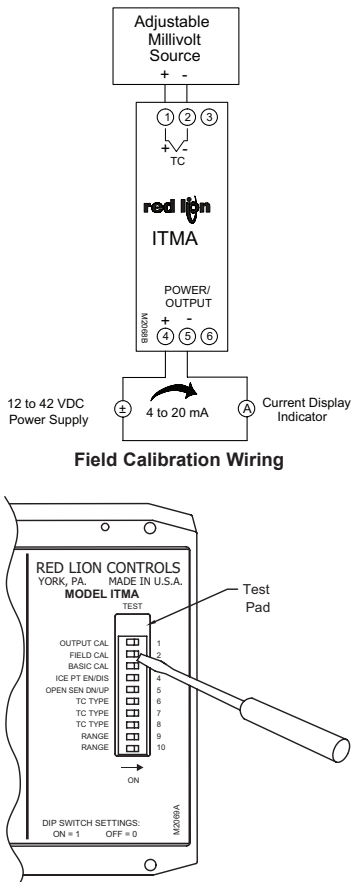

This calibration procedure can be used to assign the high and low input values if a thermocouple calibrator is not available.

*Note: To abort this calibration and reset to the previous settings, set the FIELD CAL switch OFF prior to the final OFF setting of the OUTPUT CAL switch (Step 2.12) and turn off power. Wait 5 seconds and then turn on power and the previous settings will be loaded.*

- 2.1 Connect the accurate Adjustable Millivolt Source to the TC input terminals.
- 2.2 Set the ICE PT EN/DIS switch (#4) ON to disable Ice Point Compensation.
- 2.3 Set the Type and Range for the thermocouple or mV used in your application (DIP switches #6 through #10). (TC type "J", Range 0 shown)
- 2.4 Set the FIELD CAL switch (#2) ON. [Current goes to 3.6 mA (nominal)]
- 2.5 Apply the input signal (mV equivalent for the thermocouple temperature) for the 4 mA output.
- 2.6 Set the OUTPUT CAL switch (#1) ON. [Current stays at 3.6 mA (nominal)]
- 2.7 Adjust the input signal up until the output equals 4 mA.
- 2.8 Set the OUTPUT CAL switch (#1) OFF. [Current increases to 22.3 mA (nominal)]
- 2.9 Apply the input signal (millivolt equivalent for the thermocouple temperature) for the 20 mA output.
- 2.10 Set the OUTPUT CAL switch (#1) ON. [Current decreases to 20.5 mA (nominal)]
- 2.11 Adjust the input signal down until the output equals 20 mA.
- 2.12 Set the OUTPUT CAL switch (#1) OFF.
- 2.13 Set the FIELD CAL switch (#2) OFF.
- 2.14 Set the ICE PT EN/DIS switch (#4) OFF to enable Ice Point Compensation.
- 2.15 Disconnect millivolt source from the ITMA and connect the actual sensor to be used in the application.

### 3.0 Ice Point Calibration

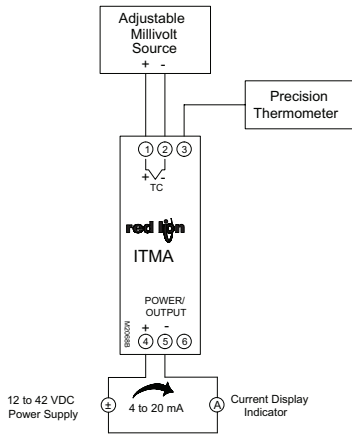

Ice Point Calibration Wiring

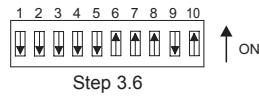
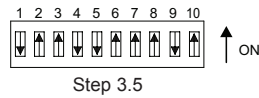
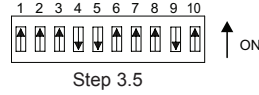
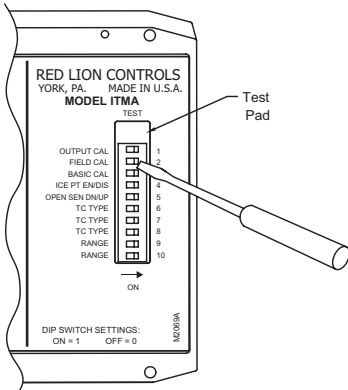

The Ice Point Calibration should only be performed with an ambient temperature between 21°C and 29°C. This Calibration was performed on the unit at the factory during the Basic Calibration and generally does not need to be done again. The Ice Point Compensation can be adjusted through this calibration. The Ice Point Calibration procedure is described below.

*Note: Calibration can be aborted by setting the BASIC CAL switch OFF prior to the setting of the OUTPUT CAL switch OFF. (Step 3.6)*

- 3.1 Connect a precision mV source with an accuracy of 0.02% to Terminal #1 TC+ Input and Terminal #2 TC- Input. Set the OUTPUT CAL switch (#1) and ICE PT EN/DIS switch (#4) OFF. Set the BASIC CAL (#3) and FIELD CAL (#2) switches ON. The positions of switches #5 thru #10 are not relevant for this calibration procedure.
- 3.2 Connect a precision thermometer (accuracy of 0.1°C) to the unused terminal (#3) beside the TC Input terminals.
- 3.3 Apply power and allow a 30 minute warm-up period. [Current goes to 3.5 mA (nominal)]
- 3.4 Using the temperature indicated by the precision thermometer, input an equivalent 1 mV/°C signal to the TC Input terminals and wait 5 seconds.
- 3.5 Set the OUTPUT CAL switch (#1) ON and then OFF.
- 3.6 Set the BASIC CAL switch (#3) and FIELD CAL switch (#2) OFF. [Current increases to 3.6 mA (nominal) or more]

## 4.0 Basic Calibration

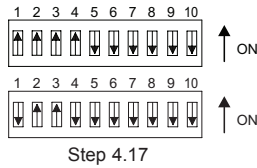
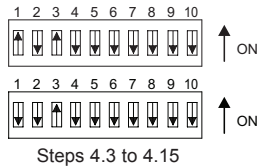
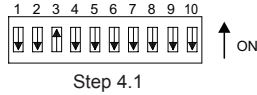
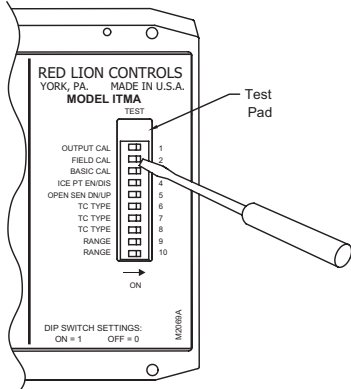
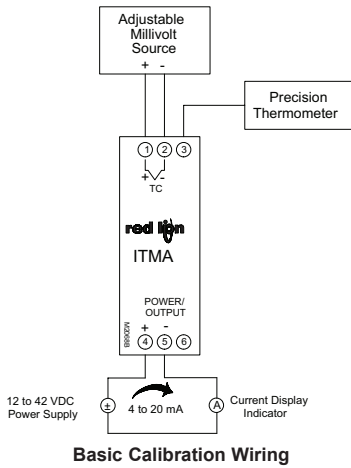

The Basic Calibration should only be performed with an ambient temperature between 21°C and 29°C. The Basic Calibration was performed on the unit at the factory and generally does not need to be done again. This procedure initializes the unit by calibrating the input, and the Ice Point Compensation. The Basic Calibration should be performed only if a condition exists as described in the “Calibration Malfunction” section. After completion of this calibration, the unit needs to be scaled in Field Calibration. The Basic Calibration procedure is described below.

*Note: To abort this calibration and reset to the previous settings, set the BASIC CAL switch OFF prior to the final setting of the OUTPUT CAL switch (Step 4.17) and turn off power for 5 seconds. Then turn on power and the previous settings will be loaded.*

- 4.1 Connect a precision mV source with an accuracy of 0.02% to Terminal #1 (TC+ Input) and Terminal #2 (TC- Input). Set the ICE PT EN/DIS switch (#4), RANGE (#9&#10), TYPE (#6, #7, and #8), OUTPUT CAL (#1), and FIELD CAL (#2) switches OFF. Set the BASIC CAL switch (#3) ON.
- 4.2 Apply power and allow a 30 minute warm-up period. [Current goes to 3.5 mA (nominal)]
- 4.3 Set the OUTPUT CAL switch (#1) ON and then OFF.
- 4.4 Input -9 mV and wait 5 seconds.
- 4.5 Set the OUTPUT CAL switch (#1) ON and then OFF.
- 4.6 Input 6 mV and wait 5 seconds.
- 4.7 Set the OUTPUT CAL switch (#1) ON and then OFF.
- 4.8 Input 22 mV and wait 5 seconds.
- 4.9 Set the OUTPUT CAL switch (#1) ON and then OFF.
- 4.10 Input 41mV and wait 5 seconds.
- 4.11 Set the OUTPUT CAL switch (#1) ON and then OFF.
- 4.12 Input 63 mV and wait 5 seconds.
- 4.13 Set the OUTPUT CAL switch (#1) ON and then OFF.
- 4.14 Input 77 mV and wait 5 seconds.
- 4.15 Set the OUTPUT CAL switch (#1) ON and then OFF.
- 4.16 Ice Point Calibration.
  - a. If ice point calibration is not desired, go to step 4.17.
  - b. To Enable ice point calibration, set the FIELD CAL switch (#2) ON.
    1. Connect a precision thermometer (accuracy of 0.1°C) to the unused terminal beside the TC Input terminals.
    2. Allow 5 minutes for the temperature to equalize.
    3. Using the temperature indicated by the precision thermometer, input an equivalent 1 mV/°C signal to the TC Input terminals.
- 4.17 Set the OUTPUT CAL switch (#1) ON and then OFF.
- 4.18 Set the BASIC CAL switch (#3) and FIELD CAL switch (#2) OFF. [Current increases to 3.6 mA (nominal) or more]
- 4.19 Perform a Field Calibration. (See Section 1.0)

## INSTALLATION

The unit is equipped with a universal mounting foot for attachment to standard DIN style mounting rails, including G profile rail according to EN50035 - G32, and top hat (T) profile rail according to EN50022 - 35 x 7.5 and 35 x 15. The unit should be installed in a location that does not exceed the maximum operating temperature and provides good air circulation. Placing the unit near devices that generate excessive heat should be avoided.

### G Rail Installation

To install the ITMA on a "G" style DIN rail, angle the module so that the upper groove of the "foot" catches under the lip of the top rail. Push the module toward the rail until it snaps into place. To remove a module from the rail, push up on the bottom of the module while pulling out away from the rail.

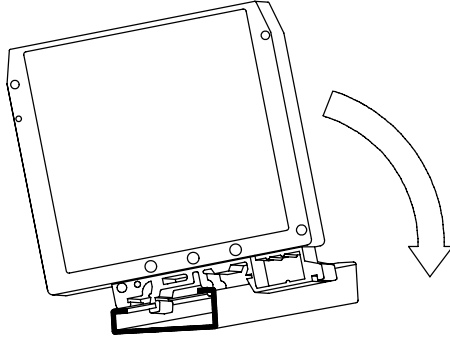

### T Rail Installation

To install the ITMA on a "T" style rail, angle the module so that the top groove of the "foot" is located over the lip of the top rail. Push the module toward the rail until it snaps into place. To remove a module from the rail, insert a screwdriver into the slot on the bottom of the "foot", and pry upwards on the module until it releases from the rail.

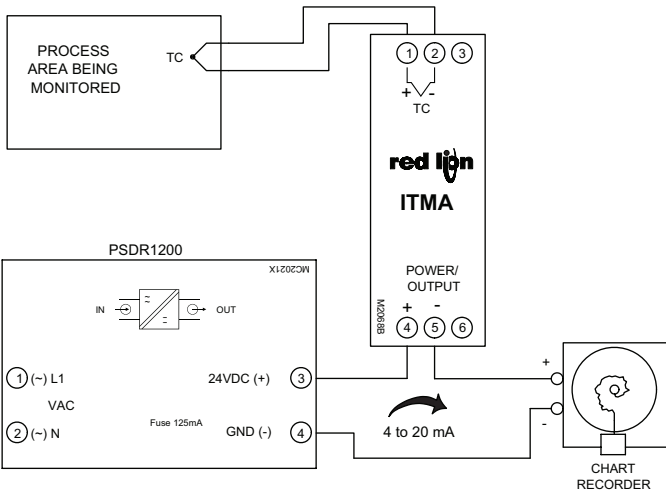
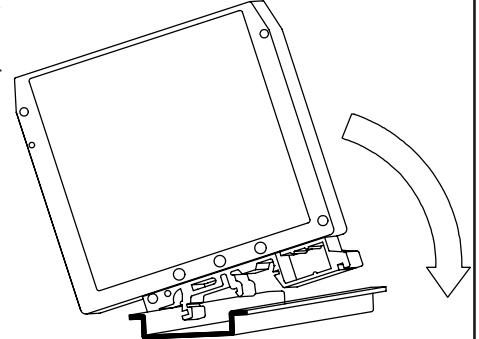

## APPLICATION

A meat processing plant needs to keep daily records of the process area temperature. FDA regulations require the temperature to be 22°C at all times. The ITMA can be used for this application, with the added benefit of being DIN rail mounted to save space.

The ITMA will sense the process area temperature, and transmit a 4 to 20 mA output to a chart recorder. The processing plant uses a "J" type thermocouple with a range of -136°C to 111°C. The ITMA is field calibrated to output 4 mA at 0°C and 20 mA at 44°C. See Section 1.0 for the Field Calibration procedure.

The ITMA output receives its power from a PSDR1200 Signal Conditioning Power Supply with a +24 VDC output.